

# Pneumatics and hydraulics

## Hydraulic valves

Dr. Ahmad Al-Mahasneh

# Hydraulic Valves

- Fluid power is controlled primarily through the use of control devices called *valves*.
- The selection of these valves involves not only the type but also the size, actuating technique, and remote-control capability.
- There are three basic types of valves: (1) directional control valves, (2) pressure control valves, and (3) flow control valves.
- Directional control valves determine the path through which a fluid traverses a given circuit. For example, they establish the direction of motion of a hydraulic cylinder or motor. This control of the fluid path is accomplished primarily by check valves; shuttle valves; and two-way, three-way, and four-way directional control valves.
- Pressure control valves protect the system against overpressure, which may occur due to excessive actuator loads or due to the closing of a valve.
- In general pressure control is accomplished by pressure relief, pressure reducing, sequence, unloading, and counterbalance valves.
- In addition, fluid flow rate must be controlled in various lines of a hydraulic circuit. For example, the control of actuator speeds depends on flow rates.
- This type of control is accomplished through the use of flow control valves.
- Noncompensated flow control valves are used where precise speed control is not required since flow rate varies with pressure drop across a flow control valve.
- Pressure-compensated flow control valves automatically adjust to changes in pressure drop to produce a constant flow rate.

# Hydraulic Valves usage example

- A welding machine application in which a directional control valve, a check valve, and a sequence valve are used as components of a hydraulic circuit for positioning and holding parts during a welding operation.
- This particular application requires a sequencing system for fast and positive holding of these parts.
- This is accomplished by placing a sequence valve in the line leading to the second of the two hydraulic cylinders.
- When the four-way directional control valve is actuated, the first cylinder extends to the end of its stroke to complete the “positioning” cycle.
- Oil pressure then builds up, overcoming the sequence valve setting.
- This opens the sequence valve to allow oil to flow to the second cylinder so that it can extend to complete the “hold” cycle.
- The check valve allows the second cylinder to retract, along with the first cylinder, when the four-way valve is shifted to allow oil to flow to the rod end of both cylinders.

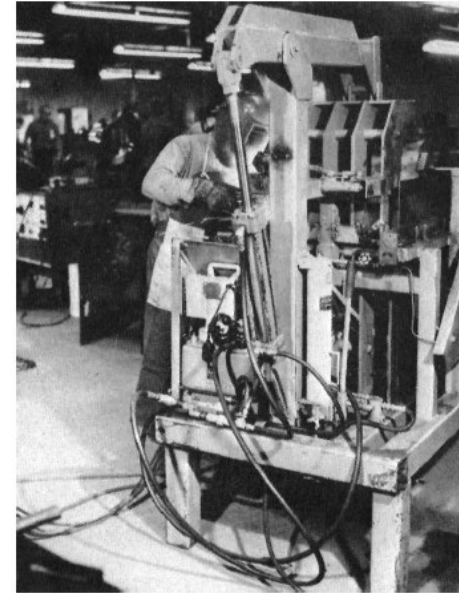

**Figure 8-1.** Welding machine application using hydraulic control valves. (Courtesy of Owatonna Tool Co., Owatonna, Minnesota.)

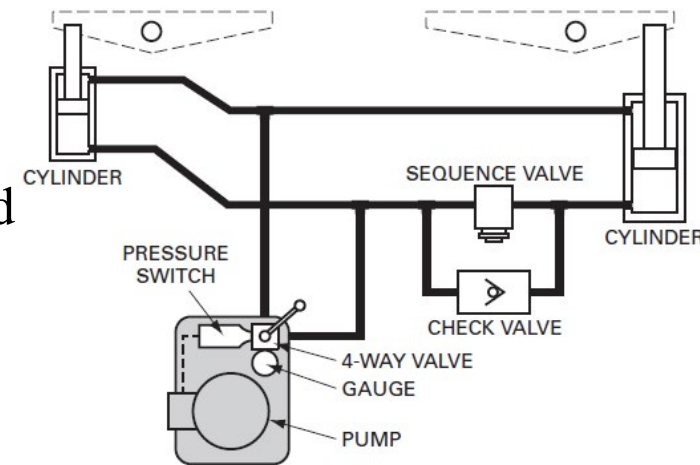

**Figure 8-2.** Hydraulic circuit showing control valves used for welding application. (Courtesy of Owatonna Tool Co., Owatonna, Minnesota.)

# Directional control valves

- Directional control valves are used to control the direction of flow in a hydraulic circuit.
- Any valve (regardless of its design) contains ports that are external openings through which fluid can enter and leave via connecting pipelines.
- The number of ports on a directional control valve (DCV) is identified using the term *way*.
- Thus, for example, a valve with four ports is a four-way valve.

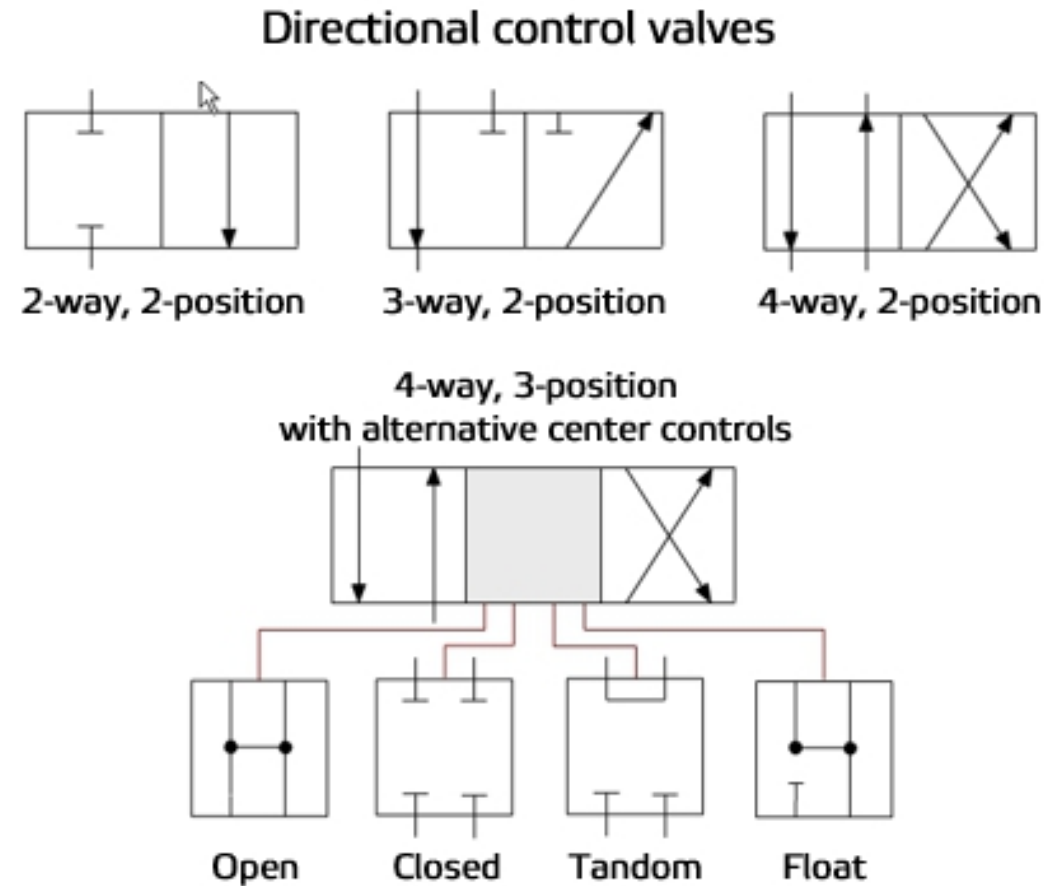

# Check Valve

- The simplest type of direction control valve is a check valve which is a two-way valve because it contains two ports.
- The purpose of a check valve is to permit free flow in one direction and prevent any flow in the opposite direction.
- Fluid flows through the valve in the space between the seat and poppet.
- A light spring holds the poppet in the closed position. In the free-flow direction, the fluid pressure overcomes the spring force at about 5 psi.
- If flow is attempted in the opposite direction, the fluid pressure pushes the poppet (along with the spring force) in the closed position. Therefore, no flow is permitted.
- The higher the pressure, the greater will be the force pushing the poppet against its seat.
- Thus, increased pressure will not result in any tendency to allow flow in the no-flow direction.



**Figure 8-3.** Check valve. (Courtesy of Sperry Vickers, Sperry Rand Corp., Troy, Michigan.)

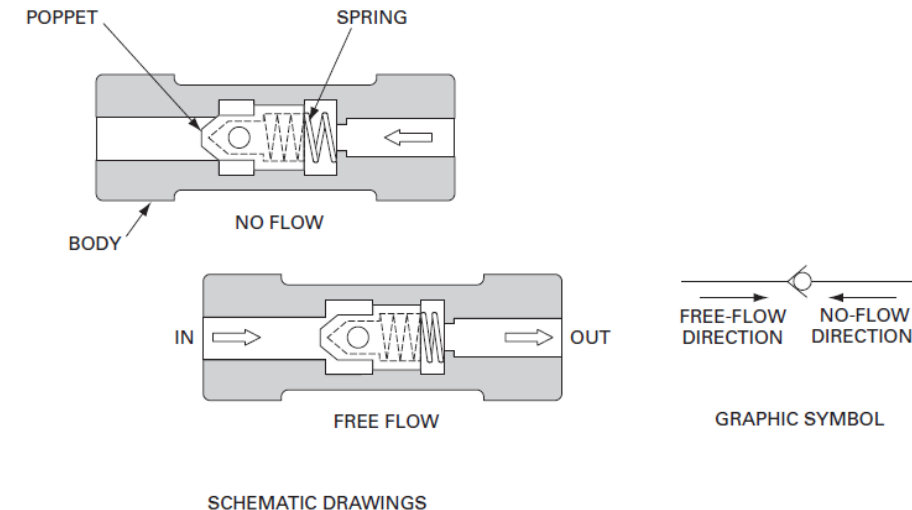

**Figure 8-4.** Operation of check valve. (Courtesy of Sperry Vickers, Sperry Rand Corp., Troy, Michigan.)

# Pilot-Operated Check Valve

- A second type of check valve is the pilot-operated check valve.
- This type of check valve always permits free flow in one direction but permits flow in the normally blocked opposite direction only if pilot pressure is applied at the pilot pressure port of the valve.
- The light spring holds the poppet seated in a no-flow condition by pushing against the pilot piston. The purpose of the separate drain port is to prevent oil from creating a pressure buildup on the bottom of the piston.
- The dashed represents the pilot pressure line connected to the pilot pressure port of the valve.
- Pilot check valves are frequently used for locking hydraulic cylinders in position.

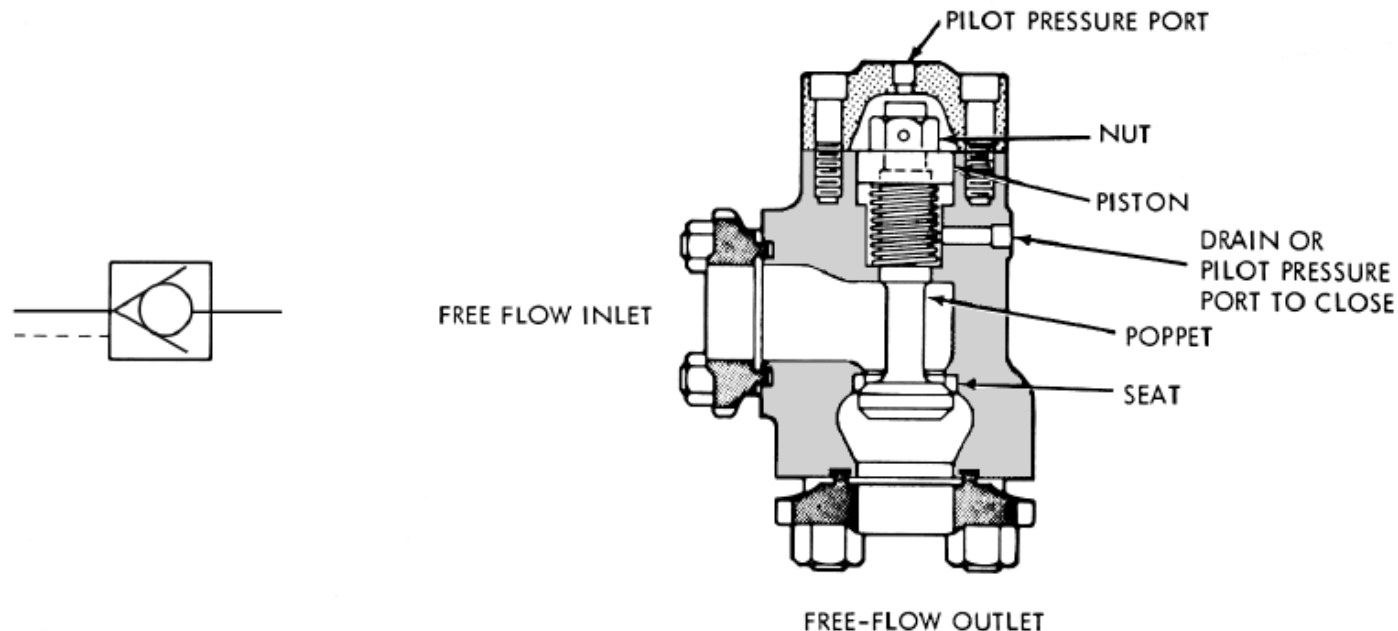

# Three-Way Valves

- Three-way directional control valves, which contain three ports, are typically of the spool design rather than poppet design.
- A spool is a circular shaft containing lands that are large diameter sections machined to slide in a very close fitting bore of the valve body.
- The radial clearance between the land and bore is usually less than 0.001 in.
- The grooves between the lands provide the flow paths between ports.
- These valves are designed to operate with two or three unique positions of the spool.
- The spool can be positioned manually, mechanically, by using pilot pressure, or by using electrical solenoids.
- Such a valve is called a three-way, two-position directional control valve.
- The flow paths are shown by two schematic drawings (one for each spool position) as well as by a graphic symbol (containing two side-by-side rectangles).
- In discussing the operation of these valves, the rectangles are commonly called “envelopes.”
- The following is a description of the flow paths through the three-way valve:
  - **Spool Position 1:** Flow can go from pump port *P* (the port connected to the pump discharge pipe) to outlet port *A* as shown by the straight line and arrow in the left envelope. In this spool position, tank port *T* (the port connected to the pipe leading to the oil tank) is blocked.
  - **Spool Position 2:** Flow can go from port *A* to port *T*. Port *P* is blocked by the spool. Note that the three ports are labeled for only one of the two envelopes
- Three-way valves are typically used to control the flow directions to and from single-acting cylinders.

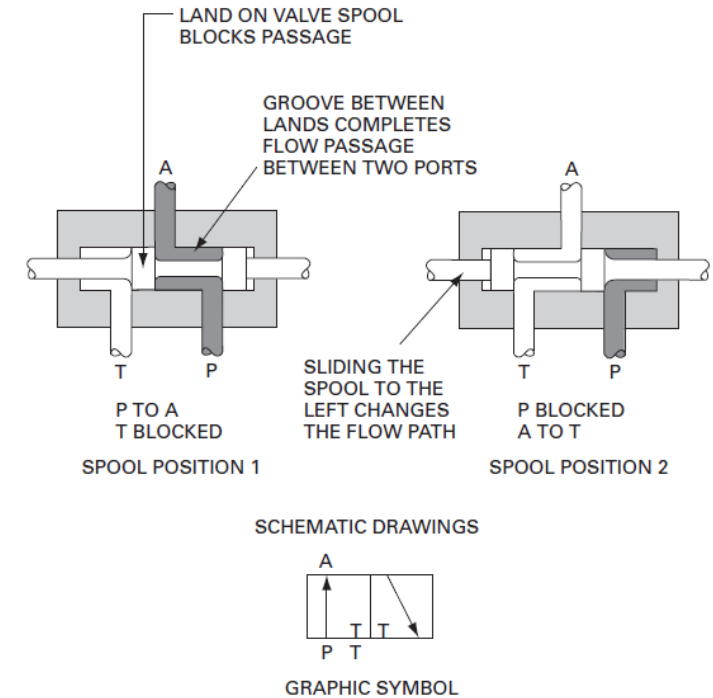

Figure 8-6. Two spool positions inside a three-way valve.

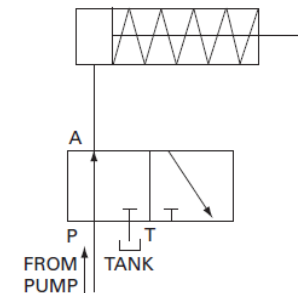

Figure 8-7. Three-way DCV controlling flow directions to and from a single-acting cylinder.

# Four-Way Valves

- A four-way, two-position directional control valve.
- Observe that fluid entering the valve at the pump port can be directed to either outlet port *A* or *B*.
- The following is a description of the flow paths through this four-way valve:
- **Spool Position 1:** Flow can go from *P* to *A* and *B* to *T*.
- **Spool Position 2:** Flow can go from *P* to *B* and *A* to *T*.
- Observe that the graphic symbol shows only one tank port *T* (for a total of four ports) even though the actual valve may have two, as shown in the schematic drawings.
- However, each tank port provides the same function, and thus there are only four different ports from a functional standpoint.
- The two internal flow-to-tank passageways can be combined inside the actual valve to provide a single tank port.
- Recall that the graphic symbol is concerned with only the function of a component and not its internal design.
- Four-way valves are typically used to control the flow directions to and from double-acting cylinders, a four-way valve permits the cylinder to both extend (left envelope) and retract (right envelope) under hydraulic pressure.

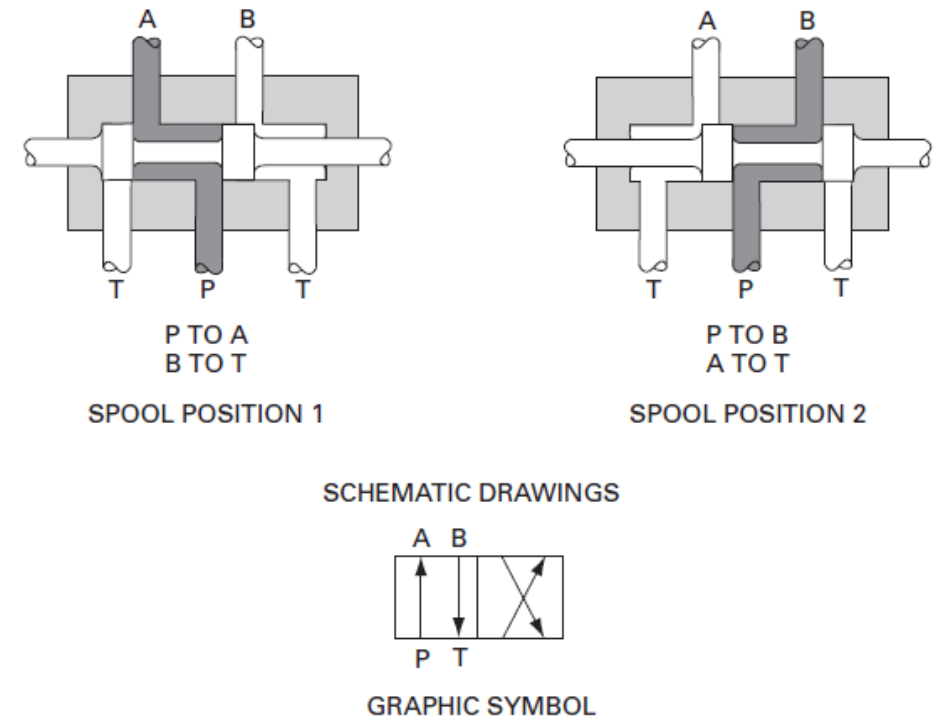

Figure 8-8. Two spool positions inside a four-way valve.

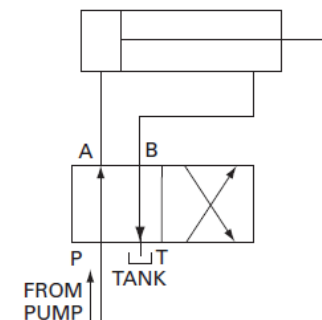

Figure 8-9. Four-way DCV controlling flow directions to and from a double-acting cylinder.



# Manually Actuated Valves

- Since the spool is spring-loaded at both ends, it is a spring-centered, three-position directional control valve.
- Thus, when the valve is unactuated (no hand force on lever), the valve will assume its center position due to the balancing opposing spring forces.
- Note in the graphic symbol that the ports are labeled on the center envelope, which represents the flow path configuration in the spring-centered position of the spool.
- Also observe the spring and lever actuation symbols used at the ends of the right and left envelopes.
- These imply a spring-centered, manually actuated valve.
- It should be noted that a three-position valve is used when it is necessary to stop or hold a hydraulic actuator at some intermediate position within its entire stroke range.
- In a two-position, four-way valve that is spring offset. In this case the lever shifts the spool, and the spring returns the spool to its original position when the lever is released.

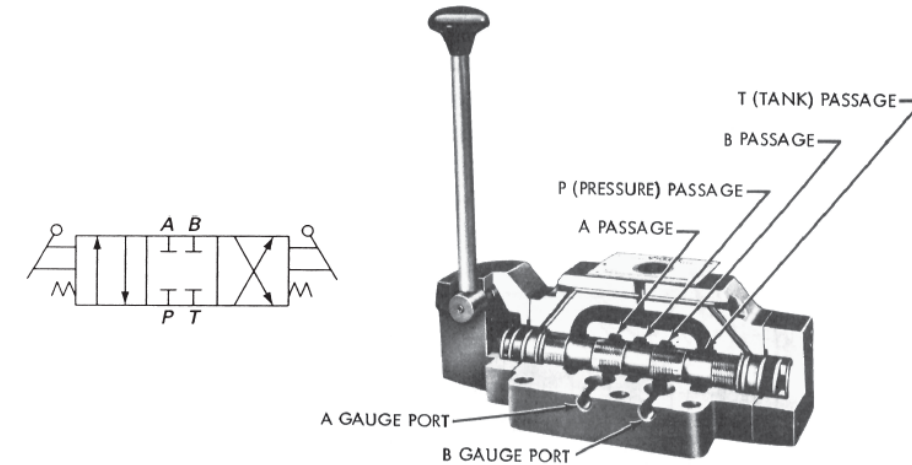

Figure 8-10. Manually actuated, spring-centered, three-position, four-way valve. (Courtesy of Sperry Vickers, Sperry Rand Corp., Troy, Michigan.)

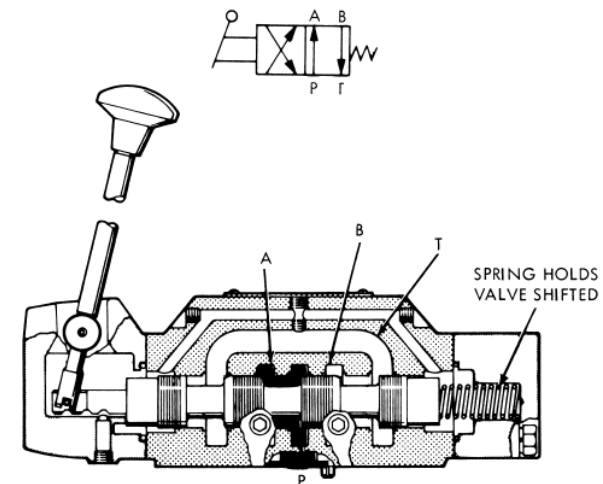
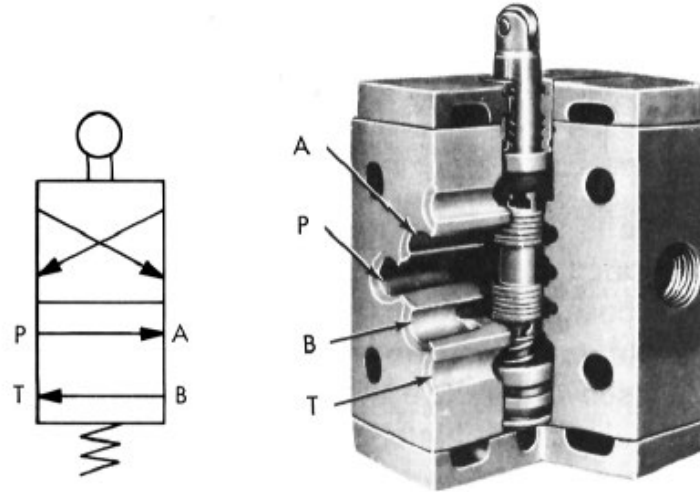

Figure 8-11. Manually actuated, two-position, spring-offset, four-way valve. (Courtesy of Sperry Vickers, Sperry Rand Corp., Troy, Michigan.)

# Mechanically Actuated Valves

- A two-position, four-way, spring-offset valve that is mechanically rather than manually actuated.
- A spool end containing a roller that is typically actuated by a cam-type mechanism.
- Note that the graphic symbol is the same except that actuation is depicted as being mechanical (the circle represents the cam-driven roller) rather than manual.



**Figure 8-12.** Mechanically actuated, spring-offset, two-position, four-way valve. (Courtesy of Sperry Vickers, Sperry Rand Corp., Troy, Michigan.)

# Pilot-Actuated Valves

- Directional control valves can also be shifted by applying air pressure against a piston at either end of the valve spool.
- Spring (located at both ends of the spool) push against centering washers to center the spool when no air is applied.
- When air is introduced through the left end passage, its pressure pushes against the piston to shift the spool to the right.
- Removal of this left end air supply and introduction of air through the right end passage causes the spool to shift to the left.
- Therefore, this is a four-way, three-position, spring-centered, air pilot-actuated directional control valve.
- The dashed lines represent pilot pressure lines.

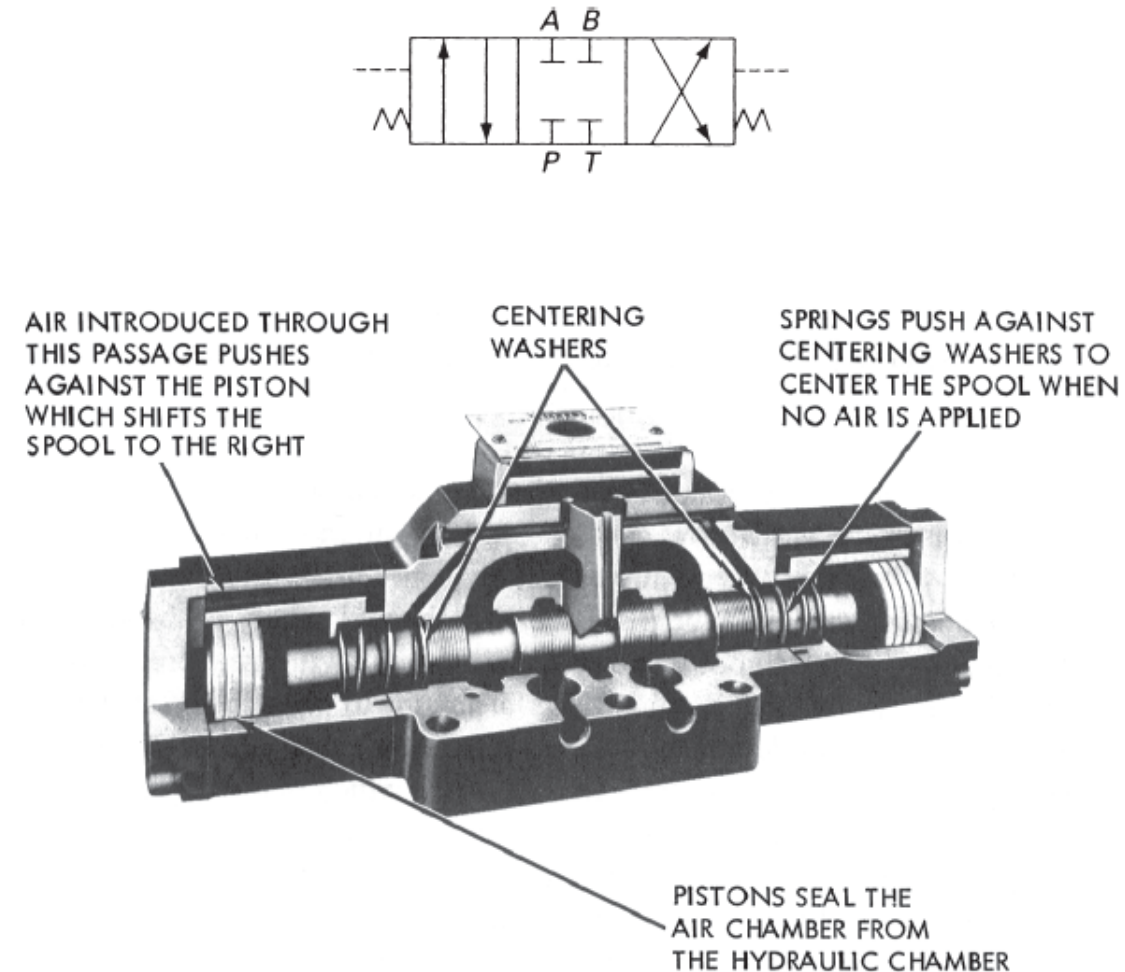
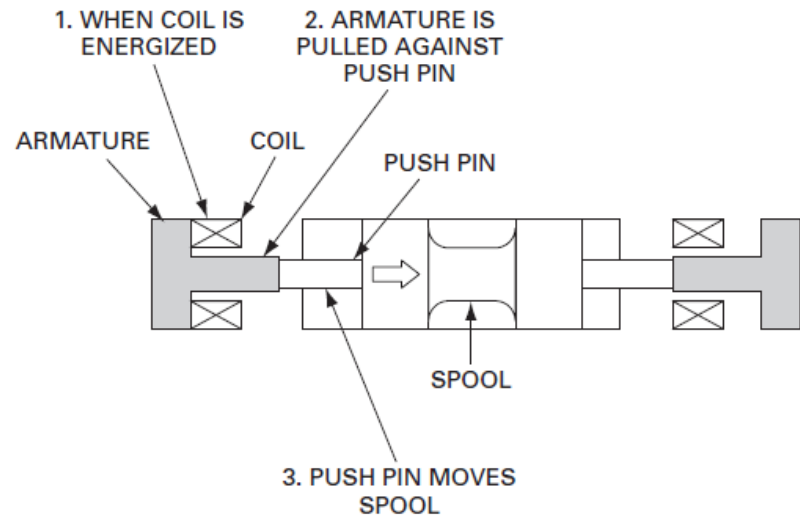

**Figure 8-13.** Air pilot-actuated, three-position, spring-centered, four-way valve. (Courtesy of Sperry Vickers, Sperry Rand Corp., Troy, Michigan.)

# Solenoid-Actuated Valves

- A very common way to actuate a spool valve is by using a solenoid.
- When the electric coil (solenoid) is energized, it creates a magnetic force that pulls the armature into the coil.
- This causes the armature to push on the push pin to move the spool of the valve.
- Solenoids are actuators that are bolted to the valve housing which gives a cutaway view of an actual solenoid-actuated directional control valve.
- Like mechanical or pilot actuators, solenoids work against a push pin, which is sealed to prevent external leakage of oil.
- There are two types of solenoid designs used to dissipate the heat created by the electric current flowing in the wire of the coil.
- The first type simply dissipates the heat to the surrounding air and is referred to as an *air gap solenoid*.
- In the second type, a *wet pin solenoid*, the push pin contains an internal passageway that allows tank port oil to communicate between the housing of the valve and the housing of the solenoid.
- Wet pin solenoids do a better job in dissipating heat because the cool oil represents a good heat sink to absorb the heat from the solenoid. As the oil circulates, the heat is carried into the hydraulic system where it can be easily dealt with.
- The fluid around the armature serves to cool it and cushion its stroke without appreciably affecting response time.
- There are no seals around this armature to wear or restrict its movement.
- This allows all the power developed by the solenoid to be transmitted to the valve spool without having to overcome seal friction. Impact loads, which frequently cause premature solenoid failure, are eliminated with this construction.
- This valve has a solenoid at each end of the spool. Specifically, it is a solenoid-actuated, four-way, three-position, spring-centered directional control valve.

# Solenoid-Actuated Valves



**Figure 8-14.** Operation of solenoid to shift spool of valve.  
(Courtesy of Sperry Vickers, Sperry Rand Corp., Troy, Michigan.)

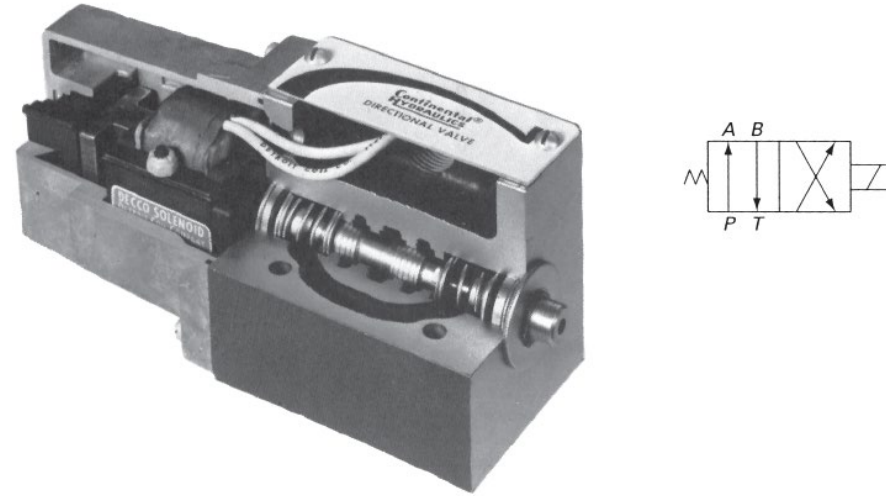

**Figure 8-16.** Single solenoid-actuated, four-way, two-position, spring-offset directional control valve. (Courtesy of Continental Hydraulics, Division of Continental Machines Inc., Savage, Minnesota.)

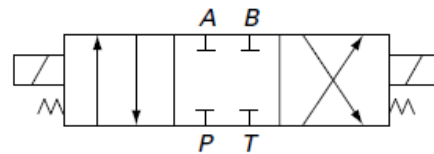

**Figure 8-15.** Solenoid-actuated, three-position, spring-centered, four-way directional control valve. (Courtesy of Continental Hydraulics, Division of Continental Machines Inc., Savage, Minnesota.)

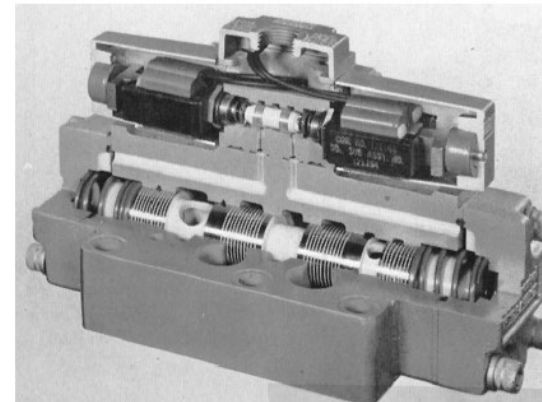

**Figure 8-17.** Solenoid-controlled, pilot-operated directional control valve. (Courtesy of Continental Hydraulics, Division of Continental Machines Inc., Savage, Minnesota.)

# Center Flow Path Configurations for Three-Position, Four-Way Valves

- Most three-position valves have a variety of possible flow path configurations.
- Each four-way valve has an identical flow path configuration in the actuated position but a different spring-centered flow path.
- Note that the open-center-type connects all ports together.
- In this design the pump flow can return directly back to the tank at essentially atmospheric pressure.
- At the same time, the actuator (cylinder or motor) can be moved freely by applying an external force.
- The closed-center design has all ports blocked.
- In this way the pump flow can be used for other parts of the circuit. At the same time, the actuator connected to ports *A* and *B* is hydraulically locked.
- This means it cannot be moved by the application of an external force.
- The tandem design also results in a locked actuator. However, it also unloads the pump at essentially atmospheric pressure.
- For example, the closed-center design forces the pump to produce flow at the high-pressure setting of the pressure relief valve.
- This not only wastes pump power but promotes wear and shortens pump life, especially if operation in the center position occurs for long periods.

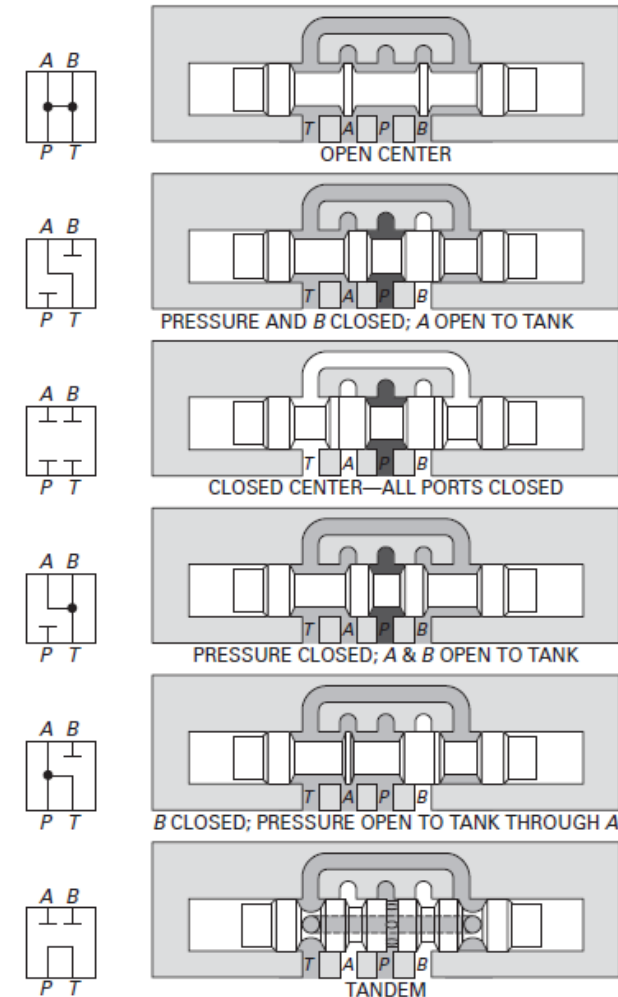

**Figure 8-18.** Various center flow paths for three-position, four-way valves. (Courtesy of Sperry Vickers, Sperry Rand Corp., Troy, Michigan.)

# Shuttle Valves

- A shuttle valve is another type of directional control valve.
- It permits a system to operate from either of two fluid power sources.
- One application is for safety in the event that the main pump can no longer provide hydraulic power to operate emergency devices.
- The shuttle valve will shift to allow fluid to flow from a secondary backup pump
- A shuttle valve consists of a floating piston that can be shuttled to one side or the other of the valve depending on which side of the piston has the greater pressure.
- Shuttle valves may be spring-loaded in one direction to favor one of the supply sources or unbiased so that the direction of flow through the valve is determined by circuit conditions.
- A shuttle valve is essentially a direct-acting double-check valve with a cross-bleed
- As shown by the double arrows on the graphic symbol, reverse flow is permitted.

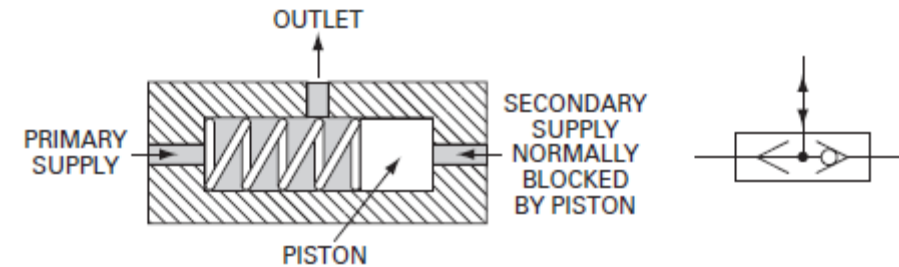
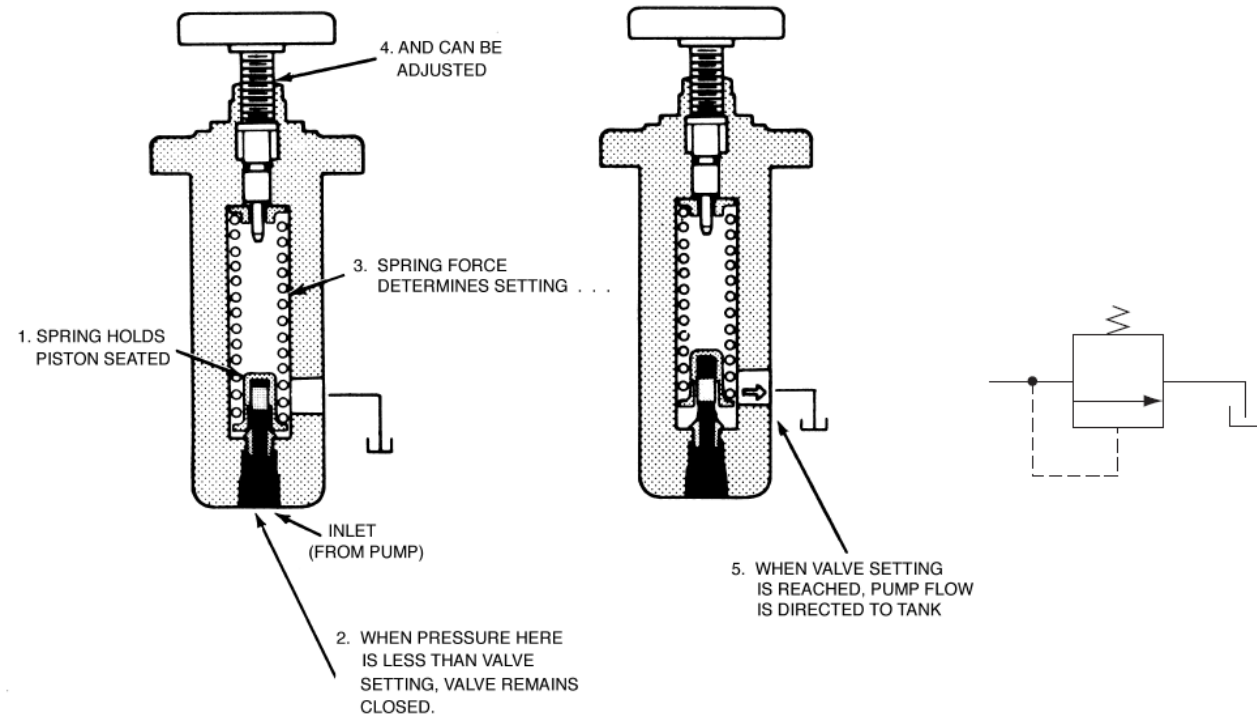

Figure 8-19. Shuttle valve (schematic and graphic symbol).

# PRESSURE CONTROL VALVES

- Simple Pressure Relief Valves

- The most widely used type of pressure control valve is the pressure relief valve, since it is found in practically every hydraulic system.
- It is normally a closed valve whose function is to limit the pressure to a specified maximum value by diverting pump flow back to the tank.
- A poppet is held seated inside the valve by the force of a stiff compression spring.
- When the system pressure reaches a high enough value, the resulting hydraulic force (acting on the piston-shaped poppet) exceeds the spring force and the poppet is forced off its seat.



**Figure 8-20.** Simple pressure relief valve. (Courtesy of Sperry Vickers, Sperry Rand Corp., Troy, Michigan.)



# PRESSURE CONTROL VALVES

## EXAMPLE 8-1

A pressure relief valve contains a poppet with a  $0.75 \text{ in}^2$  area on which system pressure acts. During assembly a spring with a spring constant of  $2500 \text{ lb/in}$  is installed to hold the poppet against its seat. The adjustment mechanism is then set so that the spring is initially compressed  $0.20 \text{ in}$  from its free-length condition. In order to pass full pump flow through the valve at the PRV pressure setting, the poppet must move  $0.10 \text{ in}$  from its fully closed position. Determine the

- Cracking pressure
- Full pump flow pressure (PRV pressure setting)

## Solution

- The force ( $F$ ) a spring exerts equals the product of the spring constant ( $k$ ) and the spring deflection ( $S$ ) from its free-length condition. Thus, the spring force exerted on the poppet when it is fully closed is

$$F = kS = 2500 \text{ lb/in} \times 0.20 \text{ in} = 500 \text{ lb}$$

In order to put the poppet on the verge of opening (cracking), the hydraulic force must equal the  $500\text{-lb}$  spring force.

$$\text{hydraulic force} = \text{spring force}$$

$$P_{\text{cracking}}A = 500 \text{ lb}$$

$$P_{\text{cracking}}(0.75 \text{ in}^2) = 500 \text{ lb} \quad \text{or} \quad P_{\text{cracking}} = 667 \text{ psi}$$

Thus, when the system pressure becomes slightly greater than  $667 \text{ psi}$ , the poppet lifts off its seat a small amount to allow fluid to begin flowing through the valve.

- When the poppet moves  $0.10 \text{ in}$  from its fully closed position, the spring has compressed a total of  $0.30 \text{ in}$  from its free-length condition. Thus, the spring force exerted on the poppet when it is opened  $0.10 \text{ in}$  to allow full pump flow is

$$F = kS = 2500 \text{ lb/in} \times 0.30 \text{ in} = 750 \text{ lb}$$

In order to move the poppet  $0.10 \text{ in}$  from its fully closed position, the hydraulic force must equal the  $750\text{-lb}$  spring force.

$$\text{hydraulic force} = \text{spring force}$$

$$P_{\text{full pump flow}}A = 750 \text{ lb}$$

$$P_{\text{full pump flow}}(0.75 \text{ in}^2) = 750 \text{ lb} \quad \text{or} \quad P_{\text{full pump flow}} = 1000 \text{ psi}$$

Thus, when system pressure reaches a value of  $1000 \text{ psi}$ , the poppet is lifted  $0.10 \text{ in}$  off its seat and the flow rate through the valve equals the pump flow rate. This means that the PRV pressure setting is  $1000 \text{ psi}$  and is  $333 \text{ psi}$  higher (or  $50\%$  higher) than the cracking pressure.

# PRESSURE CONTROL VALVES

## Pressure-Reducing Valves

- A second type of pressure control valve is the pressure-reducing valve.
- This type of valve (which is normally open) is used to maintain reduced pressures in specified locations of hydraulic systems.
- It is actuated by downstream pressure and tends to close as this pressure reaches the valve setting.
- If downstream pressure is below the valve setting, fluid will flow freely from the inlet to the outlet.
- Note that there is an internal passageway from the outlet, which transmits outlet pressure to the spool end opposite the spring.
- When the outlet (downstream) pressure increases to the valve setting, the spool moves to the right to partially block the outlet port.

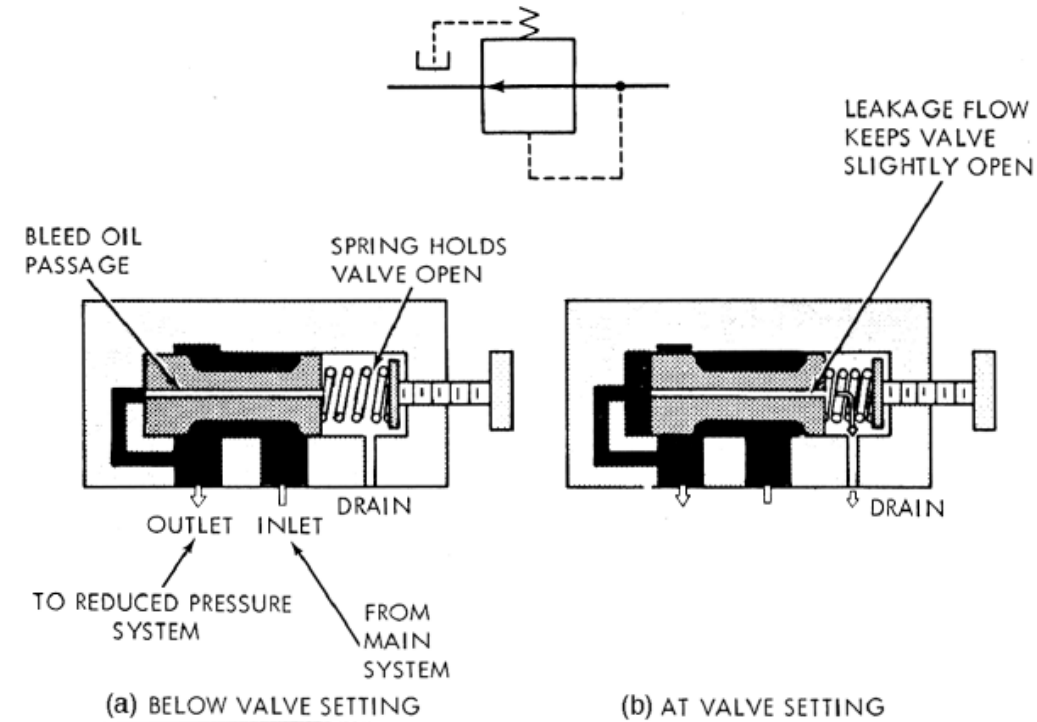
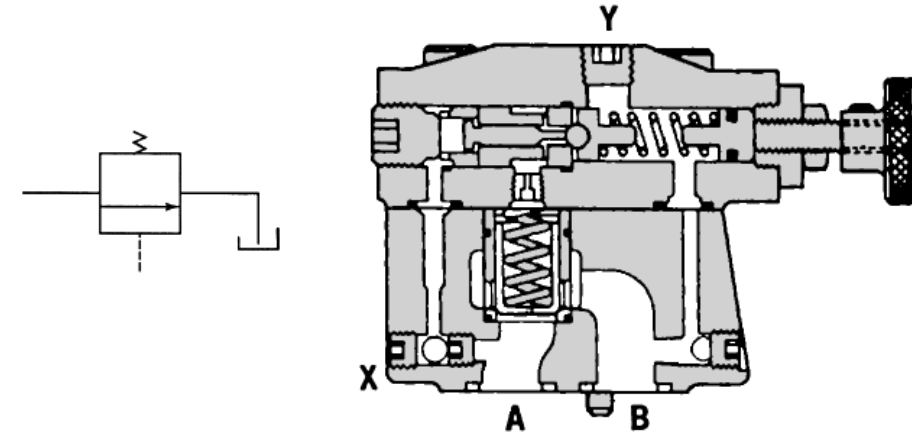

**Figure 8-26.** Operation of a pressure-reducing valve. (Courtesy of Sperry Vickers, Sperry Rand Corp., Troy, Michigan.)

# PRESSURE CONTROL VALVES

## Unloading Valves

- This valve is used to permit a pump to build pressure to an adjustable pressure setting and then allow it to discharge oil to the tank at essentially zero pressure as long as pilot pressure is maintained on the valve from a remote source. Hence, the pump has essentially no load and is therefore developing a minimum amount of power.
- This is the case in spite of the fact that the pump is delivering a full pump flow because the pressure is practically zero.
- This is not the same with a pressure relief valve because the pump is delivering full pump flow at the pressure relief valve setting and thus is operating at maximum power conditions.



**Figure 8-27.** Schematic of unloading valve. (Courtesy of Abex Corp., Denison Division, Columbus, Ohio.)

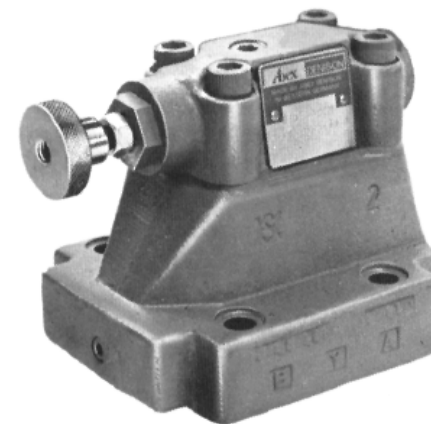

**Figure 8-28.** Unloading valve. (Courtesy of Abex Corp., Denison Division, Columbus, Ohio.)

# PRESSURE CONTROL VALVES

## EXAMPLE 8-2

A pressure relief valve has a pressure setting of 1000 psi. Compute the horsepower loss across this valve if it returns all the flow back to the tank from a 20-gpm pump.

*Solution*

$$HP = \frac{pQ}{1714} = \frac{(1000)(20)}{1714} = 11.7 \text{ hp}$$

## EXAMPLE 8-3

An unloading valve is used to unload the pump of Example 8-2. If the pump discharge pressure (during unloading) equals 25 psi, how much hydraulic horsepower is being wasted?

*Solution*

$$HP = \frac{pQ}{1714} = \frac{(25)(20)}{1714} = 0.29 \text{ hp}$$

# PRESSURE CONTROL VALVES

## Sequence Valves

- The sequence valve is designed to cause a hydraulic system to operate in a pressure sequence.
- After the components connected to port *A* have reached the adjusted pressure of the sequence valve, the valve passes fluid through port *B* to do additional work in a different portion of the system.
- The high-flow poppet of the sequence valve is controlled by the spring-loaded cone. Flow entering at port *A* is blocked by the poppet at low pressures.
- The pressure signal at *A* passes through orifices to the topside of the poppet and to the cone.
- There is no flow through these sections until the pressure rises at *A* to the maximum permitted by the adjustably set spring-loaded cone.
- When the pressure at *A* reaches that value, the main poppet lifts, passing flow to port *B*.
- It maintains the adjusted pressure at port *A* until the pressure at *B* rises to the same value.
- A small pilot flow (about 1/4 gpm) goes through the control piston and past the pilot cone to the external drain at this time.
- When the pressure at *B* rises to the pressure at *A*, the control piston seats and prevents further pilot flow loss.
- The main poppet opens fully and allows the pressure at *A* and *B* to rise to higher values together.
- Flow may go either way at this time.
- The spring cavity of the control cone drains externally from port *Y*, generally to the tank.
- This sequence valve may be remotely controlled from vent port *X*.

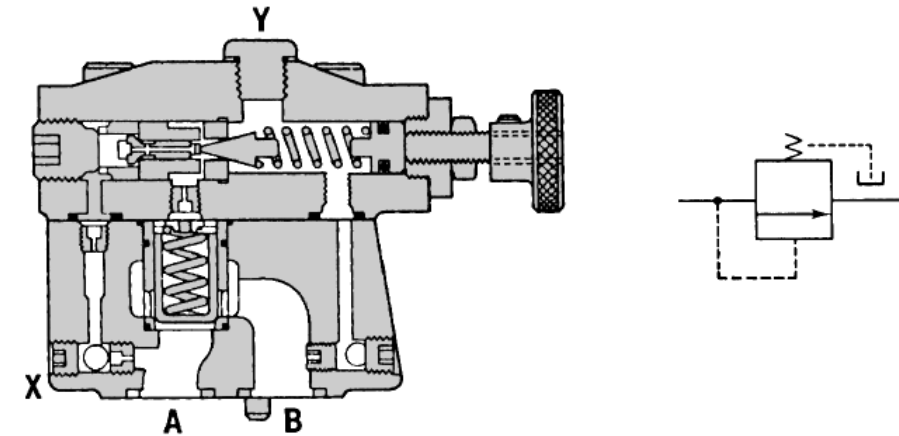
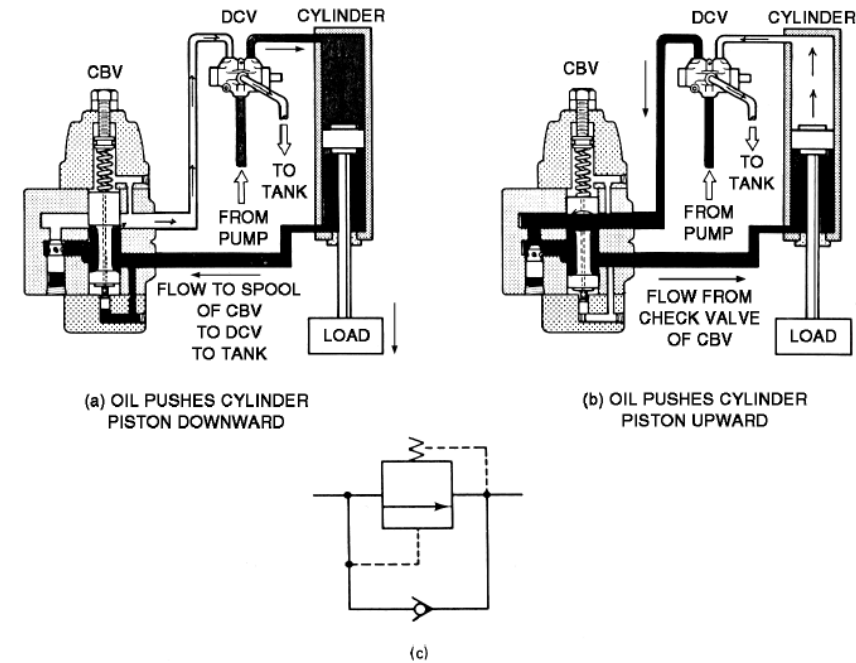

Figure 8-29. Schematic of sequence valve. (Courtesy of Abex Corp., Denison Division, Columbus, Ohio.)

# PRESSURE CONTROL VALVES

- The counterbalance valve (CBV).
- The purpose of a counterbalance valve is to maintain control of a vertical hydraulic cylinder to prevent it from descending due to the weight of its external load.
- the primary port of this valve is connected to the bottom of the cylinder, and the secondary port is connected to a directional control valve (DCV).
- The pressure setting of the counterbalance valve is somewhat higher than is necessary to prevent the cylinder load from falling due to its weight.
- when pump flow is directed (via the DCV) to the top of the cylinder, the cylinder piston is pushed downward.
- This causes pressure at the primary port to increase to a value above the pressure setting of the counterbalance valve and thus raise the spool of the CBV.
- This then opens a flow path through the counterbalance valve for discharge through the secondary port to the DCV and back to the tank.



# FLOW CONTROL VALVES

- Orifice as a Flow Meter or Flow Control Device

- Such a device can be used as a flowmeter by measuring the pressure drop ( $\Delta p$ ) across the orifice. This is because for a given orifice, there is a unique relationship between ( $\Delta p$ ) and  $Q$  (the flow rate through the orifice and thus the flow rate in the pipe).
- It can be shown that the following English-units equation relates the ( $\Delta p$ ) vs.  $Q$  relationship for an orifice installed in a pipe to measure liquid flow rate.

$$Q = 38.1 CA\sqrt{\frac{\Delta p}{SG}}$$

or, in metric units,

$$Q = 0.0851 CA\sqrt{\frac{\Delta p}{SG}} \quad (8-1M)$$

where  $Q$  = flow rate (gpm, Lpm),  
 $C$  = flow coefficient ( $C = 0.80$  for sharp-edged orifice,  $C = 0.60$  for square-edged orifice),  
 $A$  = area of orifice opening (in<sup>2</sup>, mm<sup>2</sup>),  
 $\Delta p = p_1 - p_2$  = pressure drop across orifice (psi, kPa),  
 $SG$  = specific gravity of flowing fluid.

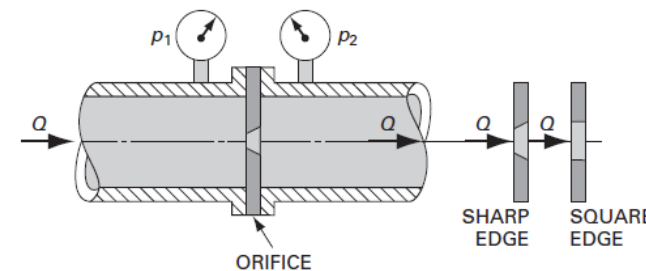

Figure 8-31. Orifice flowmeter.

---

## 1 INTRODUCTION

- The process of increasing the pressure of a gas (usually air), by reducing its volume is called compression.
- A compressor is a mechanical device that is used to compress gases.
- A compressor compresses the low pressure gas and delivers it at a higher pressure in the right quality.

### Working Principle

- Compressor is a work absorbing device.
- It increases the pressure of a gas by doing work on it.
- This means it requires work input and a prime mover is required for its working.
- The most common choice for a prime mover is the electric motor, but IC engine or a turbine can also be used.

### Air compressors

- A compressor used for compressing air is called an air compressor.
- Air from atmosphere is sucked into the compressor.
- The compressor then compresses air to a high pressure and delivers it to a storage tank (reservoir).
- From the reservoir compressed air can be supplied to desired locations through pipe lines.

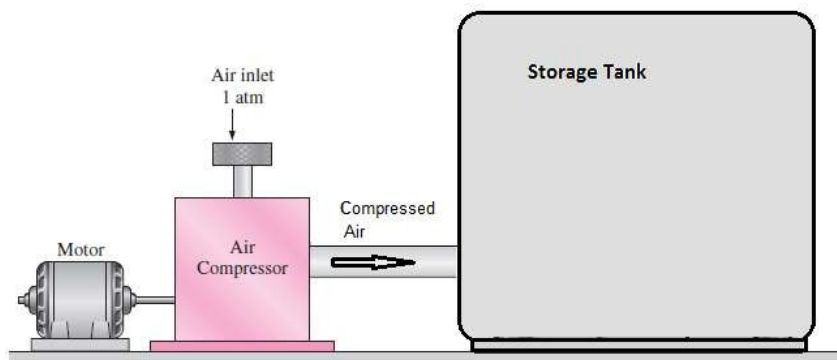

**Figure 1:** Schematic diagram of an Air Compressor unit.

---



## 2 INDUSTRIAL USES OF COMPRESSED AIR

Air compressors are used for supplying high-pressure air. Compressed air accounts for about 10% of the global energy used in industry today. There are many uses of high-pressure air in the industry.

The main uses of compressed air are :

- In compressed air engines (air motors) used in coal mines,
- Fuel injectors; to inject or spray fuel into the cylinder of a Diesel engine.
- Operating pneumatic machines and equipments such as drills, hammers etc.
- Air brakes for locomotives and railway carnages, buses and trucks.
- Water pumps and sprays paint machines,
- For starting of aircraft engines and large (heavy) Diesel engines,
- For industrial cleaning; such as to clean workshop machines, generators, automobiles etc.,
- To operate blast furnaces and gas turbine plants.
- Supercharging in I.C. engines.

### Applications of Compressors:

- We may not realize the importance of compressors in our daily life.
- But the range of application of compressors is very wide.
- From small units such as refrigerator compressors to the huge industrial units.
- Reciprocating compressors are most commonly used, ranging in sizes from 0.1 hp to 25 hp.
- Rotary compressors are available from small size (in cars) to 500 hp.
- Centrifugal compressors are often used in sizes ranging up to 10,000 hp.
- The type and size of the compressor depends upon its application and cost.

### 3 CLASSIFICATION OF COMPRESSORS

Depending upon on the principle of compression employed, compressors are classified into two major categories:

1. Positive displacement compressors
2. Dynamic displacement compressors

#### 3.1 Positive Displacement Compressors

- In these types of air compressors, compression is achieved by positive displacement of a solid boundary, which compress the gas in a closed compression chamber.
- The compressor may have single or multiple intakes and compression chambers.
- These compressors are capable of producing very large pressure ratios.

#### Working

- Atmospheric air is drawn into the compression chamber(s) through intake valves,
- The valves are then closed and the volume of each chamber is gradually decreased mechanically.
- As a result air gets compressed in the chambers.
- When the designed pressure is reached, the delivery valve(s) are opened and the compressed air is discharged into the reservoirs.

#### Types

Based on the compression mechanism used, Positive displacement compressors are divided into two main groups:

- Reciprocating compressors
- Rotary compressors

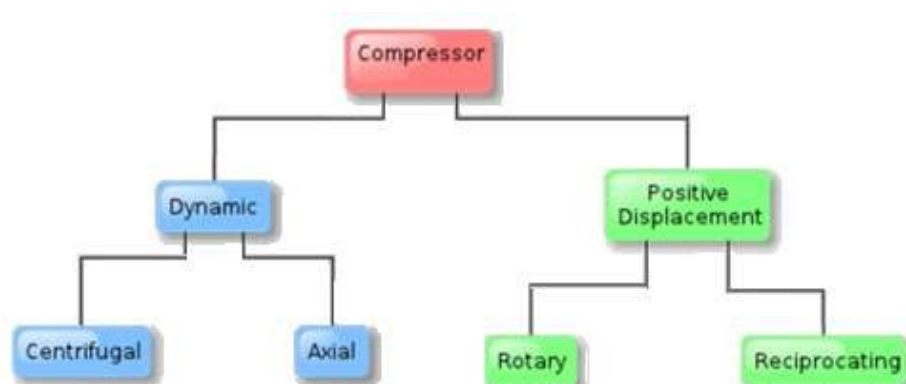

**Figure 2:** Types of Compressors.

## Dynamic Displacement Compressors

- Also called **steady flow** or **turbo-compressors**.
- The dynamic compressors have a rotating impeller.
- Here compression of gas does not occur in a closed volume.
- The flow of gas is continuous in these compressors.
- The dynamic action of impeller on the gas increases its pressure.
- They are widely used in chemical and petroleum refineries.

### Types:

Steady flow compressors are of two types:

- Centrifugal Compressor
- Axial Compressor

### Advantages :

- Can handle large quantities of air or gas at lower pressures.
- Being high speed machines, they are smaller in size,
- Provide uniform delivery of gas without requiring a large receiver,
- Deliver more clean air, as there are fewer sliding parts requiring lubrication,
- Present no balancing problems,
- Lower maintenance expenses,
- Require less operating attention.

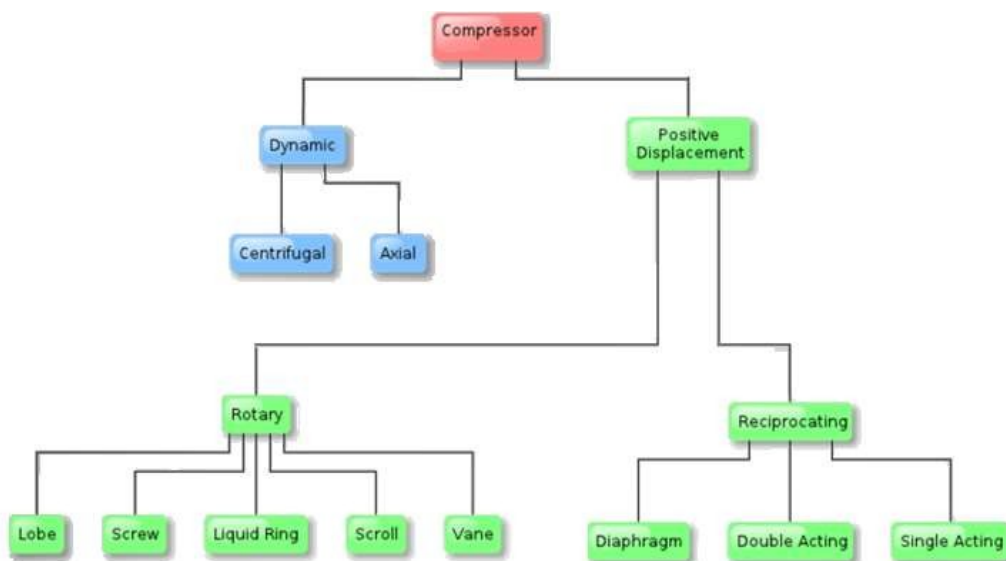

**Figure 3:** Classification of Compressor

#### 4 RECIPROCATING COMPRESSORS

- Reciprocating compressor is a positive displacement machine with constructional details similar to an IC engines.
- But, Unlike an IC engine there is no combustion of a gas to drive the piston, instead the piston is now used to compresses the gas in a closed volume.



**Figure 4 :** A Reciprocating air compressor unit.

#### Constructional details:

- A reciprocating Air Compressor consists of a piston which reciprocates inside a cylinder.
- The piston is connected to the crankshaft by means of a connecting rod and a crank.
- In this way the rotary movement of the crankshaft is converted into the reciprocating motion of the piston.
- Suction and delivery valves are provided at the top of the cylinder.

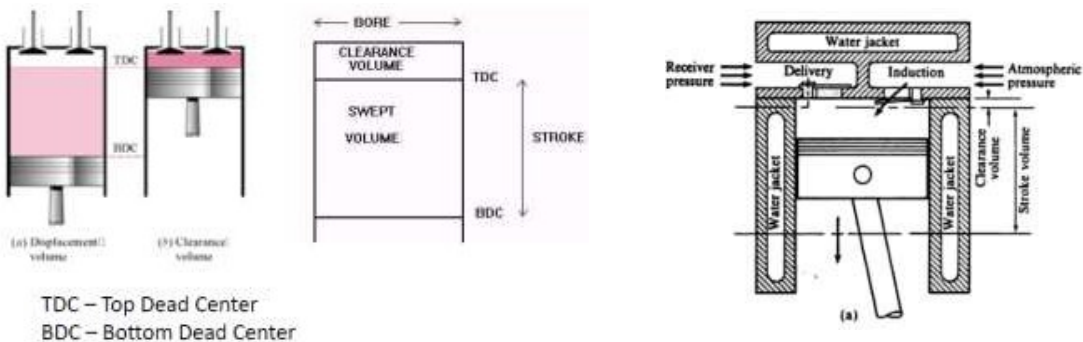

**Figure 5:** Constructional details of a single acting reciprocating air compressor.

## Working of Reciprocating Compressor:

- The whole compression cycle can be easily understood with the help of a series of processes on the  $p$ - $v$ -diagram as shown in figure-6.

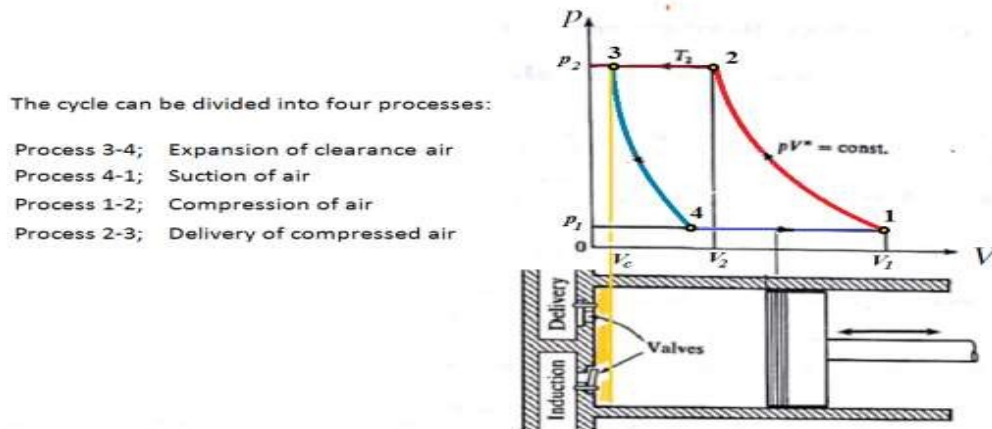

**Figure 6:** Single stage compression.

### Process 3-4; Expansion

- At the start of the cycle the piston is at its TDC or ODC position enclosing a small volume of air in the clearance space.
- This initial volume of air is called the clearance volume-  $V_C$ .
- The clearance volume is provided to prevent the piston from hitting the cylinder head and the valves.
- At the TDC/ODC position both the suction and the delivery valves are closed.
- The piston now begins its inward or the downward stroke.
- Due to the movement of the piston, air in the clearance volume expands and pressure inside the cylinder reduces.
- The expansion of clearance air continues till the cylinder pressure reaches the atmospheric value.

### Process 4-1; Suction

- With further movement of the piston, cylinder pressure falls below atmospheric.
- As a result, the air outside forces the inlet valve to open and make its way into the cylinder; this process is called suction.
- As piston continues its stroke, more and more air gets sucked into the cylinder.
- The suction process continues till the end of the down-stroke.

### Process 1-2; Compression

- At the end of suction stroke, when the piston reaches BDC or IDC position, its direction of motion is reversed because of the slider-crank mechanism.
- The piston now begins its upward stroke and the cylinder volume decreases causing an increase of air pressure.
- After a short while the pressure inside the cylinder exceeds the atmospheric pressure and as a result the inlet valve gets closed.
- The pressure of air inside the cylinder continues to increase steadily with the out-stroke of the piston.

### Process 2-3; Delivery

- When the air pressure inside the cylinder reaches the desired value, the delivery valve gets opened.
- During the remainder of the out-stroke the delivery valve stays open and the high pressure air is delivered to the storage tank.
- As the piston reaches its top dead centre position the delivery valve is closed.
- At the end of stroke, a small volume of compressed air is left in clearance space.
- The final state is now same as the initial state and the cycle gets repeated.

### 5 COMPRESSION NEGLECTING CLEARANCE VOLUME:

- For the sake of simplicity the compression cycle is first studied neglecting the clearance volume, as represented by p-v diagram; figure-7.
- During the suction stroke the air is drawn into the cylinder along line 4-1.
- All valves being closed, air is compressed along the compression curve 1-2.
- At point 2, discharge valve opens and compressed air is delivered along line 2-3.
- The net work required per cycle, for compression and the delivery of compressed air, is given by the area enclosed by the pv-diagram.

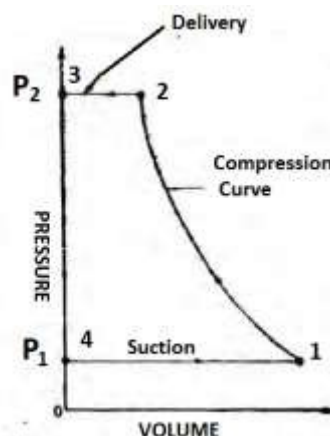

Figure 7: Compression neglecting clearance volume.

## 5.1 Types of Compression Curves

- PV diagram for compression process without clearance volume is shown in fig-8.
- Compression of air may be carried out along the following three types of curves:

1. Isentropic compression,
2. Isothermal compression
3. Polytropic compression

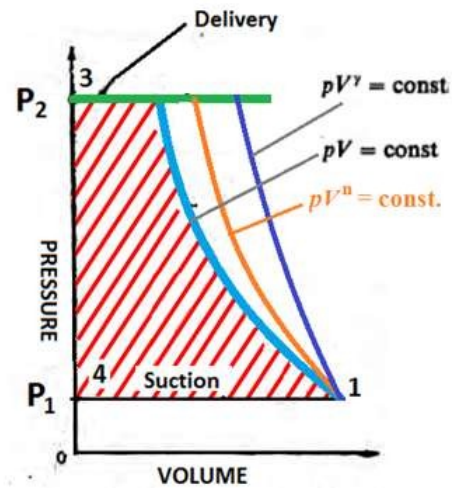

Figure 8; Types of Compression Curves.

### Isentropic compression

- If the compression occurs very rapidly in a non-conducting cylinder.
- Then there is little time available for heat transfer and the process will be nearly isentropic.
- The law for isentropic compression is

$$PV^\gamma = \text{const.}$$

### Isothermal compression

- The compression of air is now carried out slowly.
- In this case the heat of the compression gets extracted from the air by the cooling water circulating in the cylinder jackets.
- The compression will then approach isothermal conditions.
- The law for an isothermal or hyperbolic compression is

$$PV = \text{const.}$$

here the value of index  $n$  is 1.

### Polytropic compression

- In actual practice neither isentropic nor the isothermal conditions exist.
- The actual compression process is between the two; called polytropic compression.
- The compression curve follows the law:

$$PV^n = \text{const.}$$

Where,  $n$  is the index of compression.

## 6 AIR COMPRESSOR TERMINOLOGY

The following terminology should be well understood analysing the performance of air compressors.

### Free air delivered FAD

It is the volume of air delivered under the conditions of temperature and pressure existing at the compressor intake, i.e., volume of air delivered at surrounding air temperature and pressure.

### Capacity of a compressor

It is the quantity of the free air actually delivered by a compressor in cubic metres per minute.

### Swept Volume

It is the volume in cubic metres obtained as the product of the piston area in  $\text{m}^2$  and the piston stroke in metre.

### Indicated power or air power

It is the power determined from the actual indicator diagram taken during a test on the compressor.

### Shaft or brake power

It is the power delivered to the shaft of the compressor or the power required to drive the compressor. The compressor may be driven by an engine or an electric motor.

$$\text{Shaft or brake power} - \text{Air/ indicated power} = [\text{Friction power}]$$

$$\text{Mechanical efficiency, } \eta_m = \frac{\text{Air (indicated) power}}{\text{Shaft (brake) power}}$$

### Isothermal power

It is the power of a compressor calculated from the theoretical indicator diagram drawn by assuming the isothermal compression.

$$\text{Isothermal efficiency} = \frac{\text{Isothermal power in watts}}{\text{Indicated or actual power in watts}}$$

### Volumetric efficiency

It is the ratio of the actual volume of the free air at standard atmospheric conditions discharged in one delivery stroke, to the volume swept by the piston during the stroke.

$$\text{Volumetric efficiency} = \frac{\text{Volume of free air delivered per stroke}}{\text{Volume swept by piston per stroke}}$$



## 7 EFFECT OF CLEARANCE VOLUME

- The clearance space is provided in an actual compressor to prevent the piston from striking the cylinder head.
- The suction process taking place in the compressor with clearance space is different from the suction without clearance as shown in figure-8.

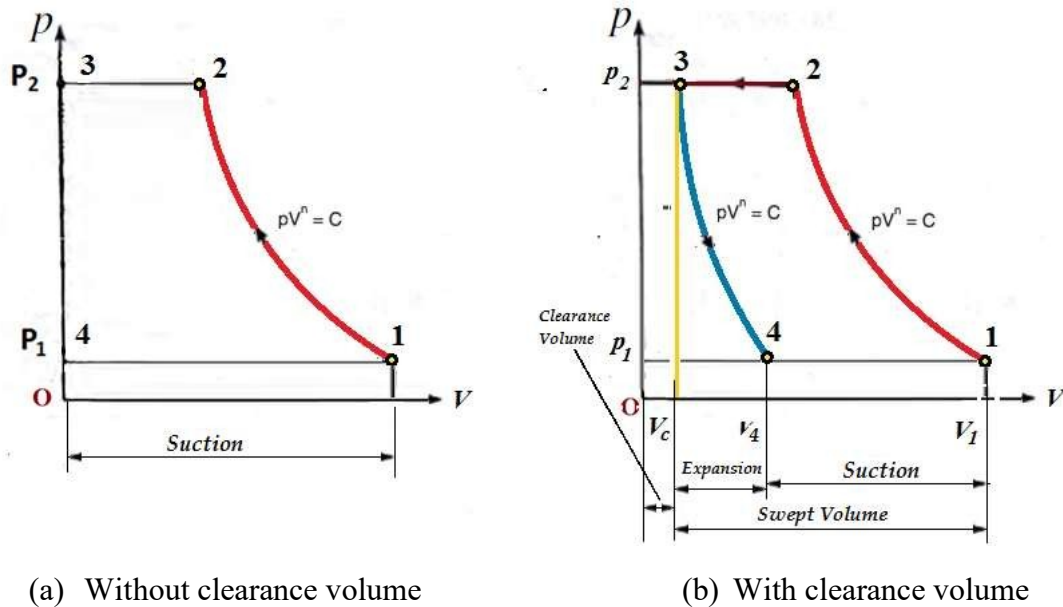

**Figure 8, Single stage polytropic compression cycle.**

- With the presence of the clearance volume, all the compressed air in the cylinder is not delivered from it at the end of stroke.
- But, a small amount of compressed air is left in the clearance space.
- This high pressure air in clearance space will first re-expand polytropically along the curve 3-4.
- At state point-4, suction valves open and the suction of fresh charge begins.
- Thus, it can be clearly seen that the volume of air drawn into the cylinder with the presence of the clearance volume gets **considerably reduced**.

Volume of suction air with clearance volume gets reduced from  $V_1$  to  $V_1 - V_c$ .

- Therefore, there occurs a significant reduction in the volumetric efficiency of the compressor due to the presence of clearance volume.
- The volumetric efficiency of compressor with clearance volume can be written as

$$\mu_{vol} = \frac{V_1 - V_4}{V_1 - V_3} = \frac{V_1 - V_4}{V_{Sw}}$$

- In practice the clearance volume is limited to, two or three per cent of the displacement or swept volume.